

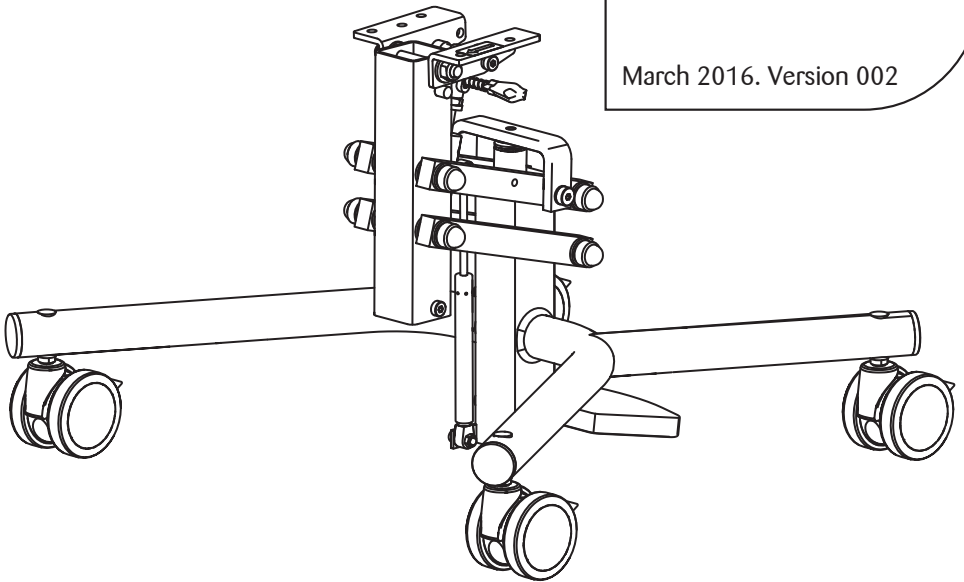

## Instruction for use part 2 of 2

# GM25

March 2016. Version 002



Read part 1 and part 2 before use





Carers and home users

Cuidadores y Usuarios  
Assistenti ed utenti  
Opiekunowie



Re-issue and stores

Reedición y Tiendas  
Ortopedie  
Sklepy



Professional and technical users

Profesionales y Usuarios Técnicos  
Terapisti e Tecnici  
Profesjonalisci

#### Product Labels

- Each Jenx product has a number of pictorial safety labels attached, please refer to the explanations below.
- El numero de serie está escrito en la pegatina CE (vea la image), que está en el producto.
- Siempre que se ponga en contacto con nosotros indiquenos este numero.
- Cada produto Jenx tem um número de etiquetas de segurança pictórica em anexo, referem-se às explicações abaixo.
- Kazdy wyrób firmy Jenx oznaczony jest szeregiem etykiet bezpieczeństwa w formie piktogramów. Ich opisy zamieszczono poniżej.



- Attention / Warning
- Regulaciones
- Attenção/ Aviso
- Attenzione/Avvertenza
- Uwaga!



- Please read Instruction for Use
- Por favor lea las intruciones
- Leia as instruções
- Leggere le istruzioni
- Prosimy, przeczytaj instrukcje



- Only for indoor use
- Solo para uso en el interior
- Apenas para utilizar em exteriores
- Solo per utilizzo al chiuso
- Tylko do użytku wewnątrz pomieszczeń



- Always fasten and adjust positioning straps and belts to suit the child. Adjust to suit changes in clothing. Allow one fingers width between the belt and the child.
- Presione y ajuste siempre las correas posicionadoras y los cinturones para que el producto sirva al niño. Ajuste siempre teniendo en cuenta los cambios de ropa. Deje siempre el espacio de un dedo de ancho entre el cinturón e el niño.
- Aperte e ajuste faixas e cintos de posicionamento para se adequar à criança. Ajuste de acordo com a mudança de roupa. Permitem largura de um dedo entre a correia e a criança.
- Allacciare le cinture e le cinghie di posizionamento e regolarle in base alle esigenze del bambino e in base agli indumenti indossati dal bambino. Verificare di riuscire a inserire un dito tra la cintura ed il bambino.
- Upewnij się, że wszystkie pasy są w użyciu



- Do not leave child unattended
- No deje el niño sin vigilancia
- NÃO UTILIZE como dispositivo de mobilidade.
- Nunca utilize o produto em solo irregular ou superfícies desniveladas.
- Nie pozostawiaj dziecka bez opieki



- DO NOT USE as a mobility device Never use product on rough ground or uneven surface.
- NO USAR ESTO PRODUCTO como un dispositivo de movilidad.
- No usar esto producto en suelo o sobre superficies irregulares.
- NÃO UTILIZE como dispositivo de mobilidade. Nunca utilize o produto em solo irregular ou superfícies desniveladas.
- NIE UŻYWAJ WYROBU, jako urządzenia transportowego. Nigdy nie korzystaj z wyrobu na nie równej, lub pochylej nawierzchni.
- User Weight Limit (changes per model and size)
- Peso limite del usuario (cambia por modelo y dimensiones)
- Limite peso de cliente (altera por modelo e tamanho)
- Portata massima (dipende dal modello e dalla misura)
- Maksymalna dopuszczalna waga użytkownika (zależna od wyrobu i jego rozmiaru)
- Conforms to CE Marking Regulations Medical Devices Directive (MDD) 93/42 EEC).
- Conformidad con la Marcación CE Regulaciones Directiva de Dispositivos Medicos(MDD) 93/42 EEC)
- Compatível com as Normas de Identificação da CE Directiva de Dispositivos Médicos (MDD) 93/42 EEC)
- Conforme alle disposizioni CE Direttiva riguardante i dispositivi medici 93/42 CEE
- Wyrób zgodny z wymaganiami zasadniczymi przepisów dot. oznakowania CEDyrektywa Wyrobów Medycznych (MDD) 93/42 EEC



# Specification

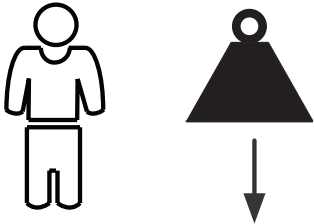
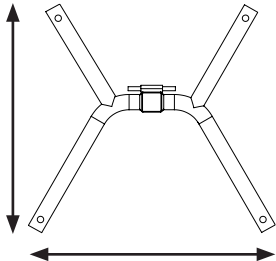
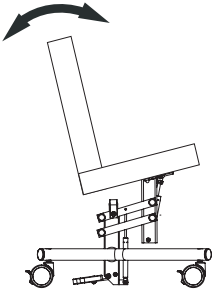

Especificación  
Dati tecnici  
Especificações  
Technické údaje

	50 kg
	600 x 615 mm
	-30° +10°

# Castors

Rodízios  
Ruedas  
Ruote  
Rolki

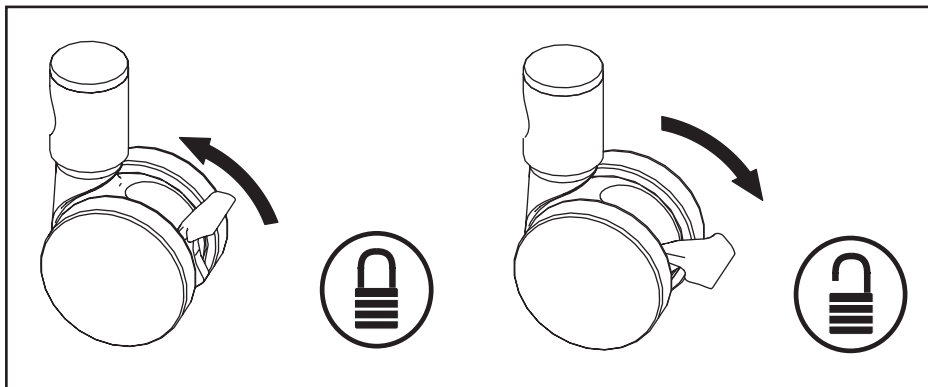

# Tilt in Space



Inclinación  
toldo  
inclinazione  
plandeka

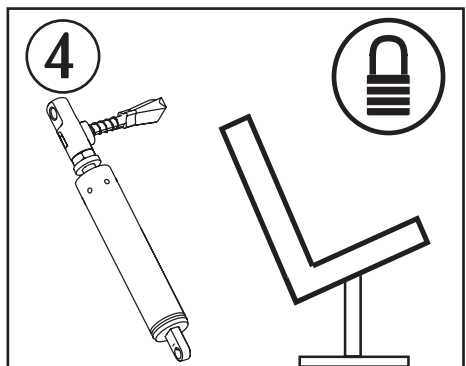
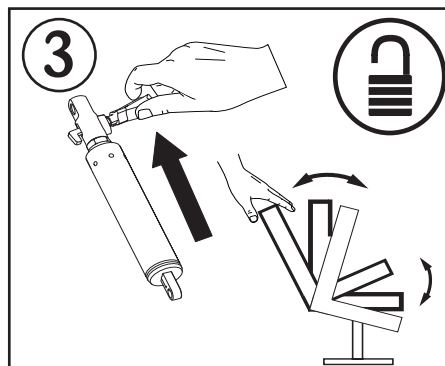
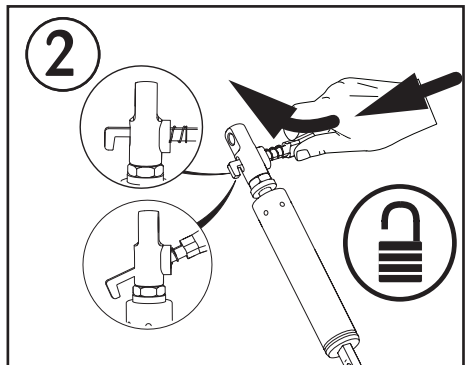
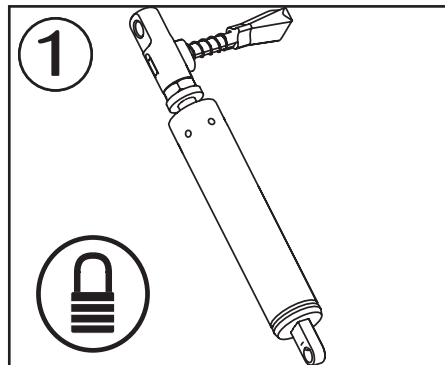
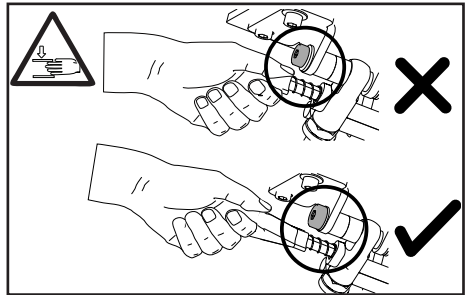
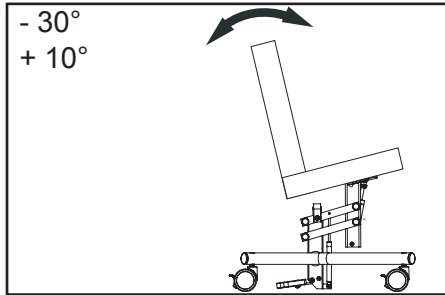

Jenx Limited, Wardsend Road, Sheffield S6 1RQ, United Kingdom  
Tel: +44 (0) 114 285 3376  
Email: [export@jenx.com](mailto:export@jenx.com)  
[www.jenx.com](http://www.jenx.com)

**JENX**®   
Positioning for life

# Chair Height/lock

altura de la silla  
altura da cadeira  
altezza della seduta  
wysokość krzesła

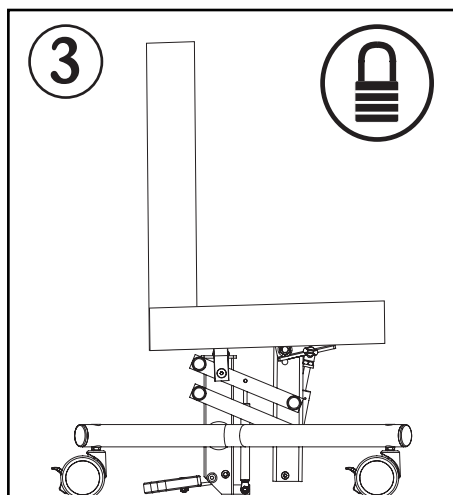
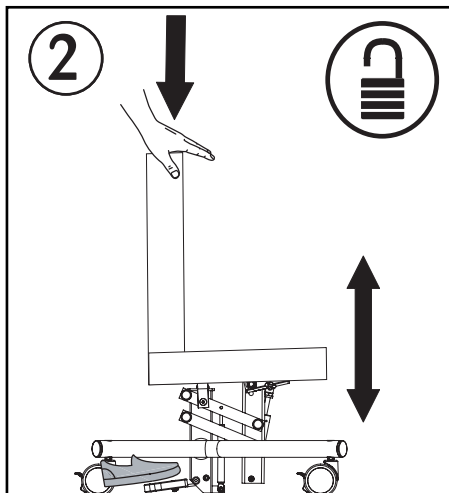
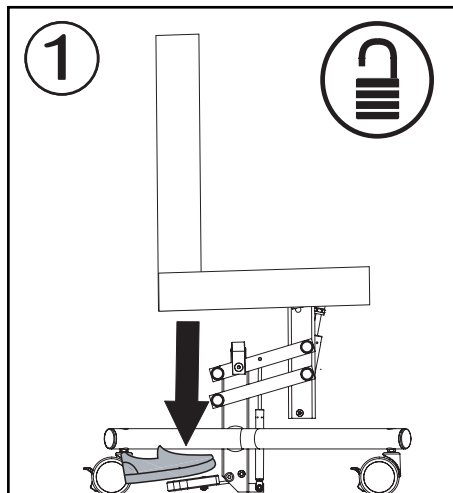

# Notes

notas  
notatki

---

Jenx Limited, Wardsend Road, Sheffield S6 1RQ, United Kingdom  
Tel: +44 (0) 114 285 3376  
Email: [export@jenx.com](mailto:export@jenx.com)  
[www.jenx.com](http://www.jenx.com)



---

Jenx Limited, Wardsend Road, Sheffield S6 1RQ, United Kingdom  
Tel: +44 (0) 114 285 3376  
Email: [export@jenx.com](mailto:export@jenx.com)  
[www.jenx.com](http://www.jenx.com)





Seating

Standing

Sleeping

Therapy



## Instruction for use part 2 of 2

# JM01

March 2016. Version 002

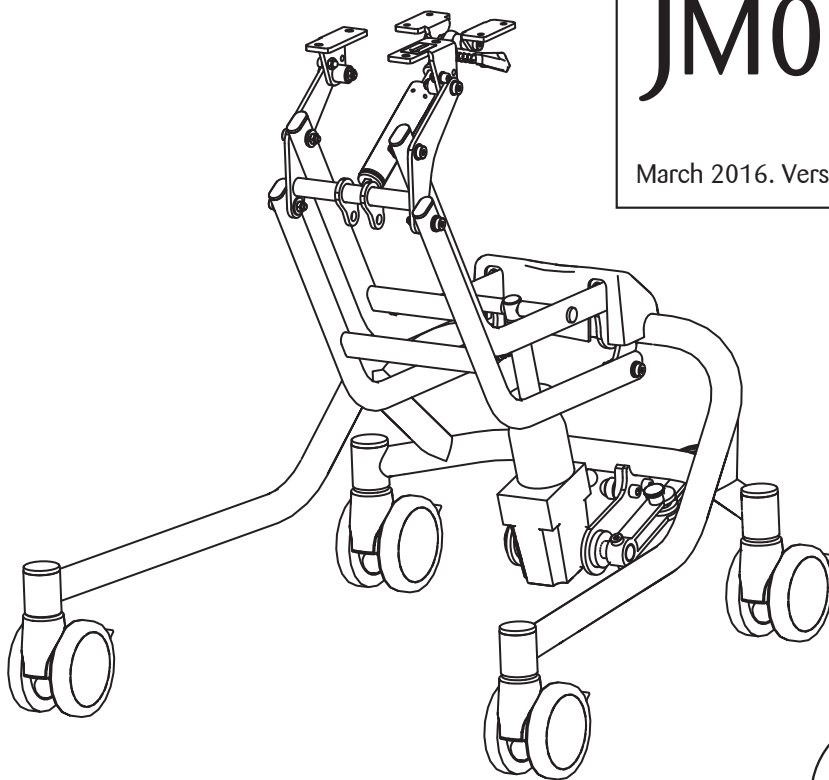

Read part 1 and part 2 before use





Carers and home users

Cuidadores y Usuarios  
Assistenti ed utenti  
Opiekunowie



Re-issue and stores

Reedición y Tiendas  
Ortopedie  
Sklepy



Professional and technical users

Profesionales y Usuarios Técnicos  
Terapisti e Tecnici  
Profesjonalisci

#### Product Labels

- Each Jenx product has a number of pictorial safety labels attached, please refer to the explanations below.
- El numero de serie está escrito en la pegatina CE (vea la image), que está en el producto.
- Siempre que se ponga en contacto con nosotros indiquenos este numero.
- Cada produto Jenx tem um número de etiquetas de segurança pictórica em anexo, referem-se às explicações abaixo.
- Kazdy wyrób firmy Jenx oznaczony jest szeregiem etykiet bezpieczeństwa w formie piktogramów. Ich opisy zamieszczono poniżej.



- Attention / Warning
- Regulaciones
- Attenção/ Aviso
- Attenzione/Avvertenza
- Uwaga!



- Please read Instruction for Use
- Por favor lea las intruciones
- Leia as instruções
- Leggere le istruzioni
- Prosimy, przeczytaj instrukcje



- Only for indoor use
- Solo para uso en el interior
- Apenas para utilizar em exteriores
- Solo per utilizzo al chiuso
- Tylko do użytku wewnątrz pomieszczeń



- Always fasten and adjust positioning straps and belts to suit the child. Adjust to suit changes in clothing. Allow one fingers width between the belt and the child.
- Presione y ajuste siempre las correas posicionadoras y los cinturones para que el producto sirva al niño. Ajuste siempre teniendo en cuenta los cambios de ropa. Deje siempre el espacio de un dedo de ancho entre el cinturón e el niño.
- Aperte e ajuste faixas e cintos de posicionamento para se adequar à criança. Ajuste de acordo com a mudança de roupa. Permitem largura de um dedo entre a correia e a criança.
- Allacciare le cinture e le cinghie di posizionamento e regolarle in base alle esigenze del bambino e in base agli indumenti indossati dal bambino. Verificare di riuscire a inserire un dito tra la cintura ed il bambino.
- Upewnij się, że wszystkie pasy są w użyciu



- Do not leave child unattended
- No deje el niño sin vigilancia
- NÃO UTILIZE como dispositivo de mobilidade.
- Nunca utilize o produto em solo irregular ou superfícies desniveladas.
- Nie pozostawiaj dziecka bez opieki



- DO NOT USE as a mobility device Never use product on rough ground or uneven surface.
- NO USAR ESTO PRODUCTO como un dispositivo de movilidad.
- No usar esto producto en suelo o sobre superficies irregulares.
- NÃO UTILIZE como dispositivo de mobilidade. Nunca utilize o produto em solo irregular ou superfícies desniveladas.
- NIE UŻYWAJ WYROBU, jako urządzenia transportowego. Nigdy nie korzystaj z wyrobu na nie równej, lub pochylej nawierzchni.



- User Weight Limit (changes per model and size)
- Peso limite del usuario (cambia por modelo y dimensiones)
- Limite peso de cliente (altera por modelo e tamanho)
- Portata massima (dipende dal modello e dalla misura)
- Maksymalna dopuszczalna waga użytkownika (zależna od wyrobu i jego rozmiaru)



- Conforms to CE Marking Regulations Medical Devices Directive (MDD) 93/42 EEC).
- Conformidad con la Marcación CE Regulaciones Directiva de Dispositivos Medicos(MDD) 93/42 EEC)
- Compatível com as Normas de Identificação da CE Directiva de Dispositivos Médicos (MDD) 93/42 EEC)
- Conforme alle disposizioni CE Direttiva riguardante i dispositivi medici 93/42 CEE
- Wyrób zgodny z wymaganiami zasadniczymi przepisów dot. oznakowania CEDyrektywa Wyrobów Medycznych (MDD) 93/42 EEC

# Specification

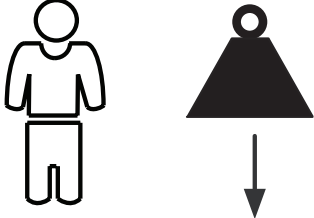
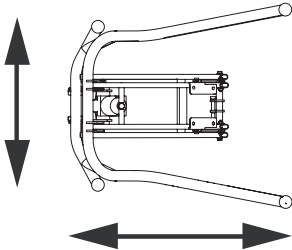
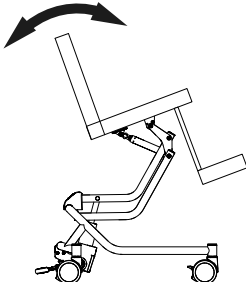

Especificación  
Dati tecnici  
Especificações  
Technické údaje

	50 kg
	760 x 650 mm
	-30° +10°

# Castors

Rodízios  
Ruedas  
Ruote  
Rolki

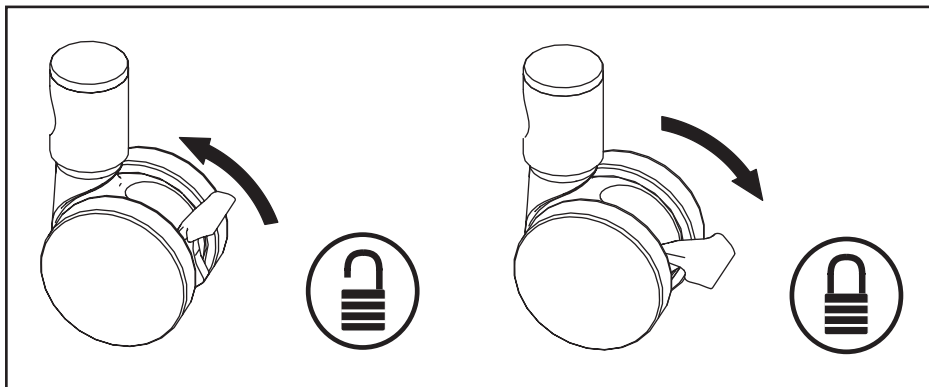

# Tilt in Space



Inclinación  
toldo  
inclinazione  
plandeka

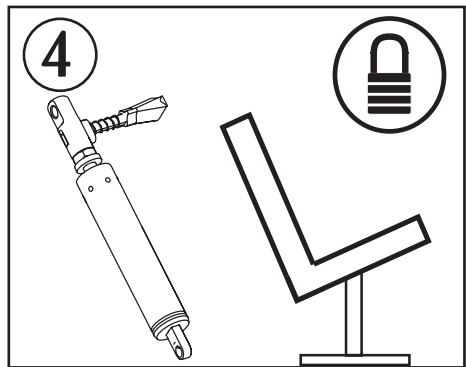
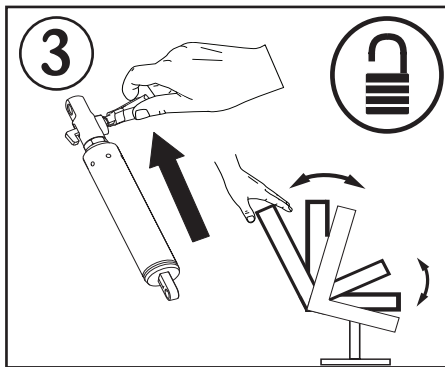
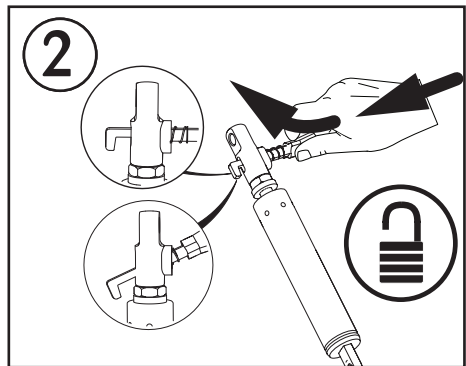
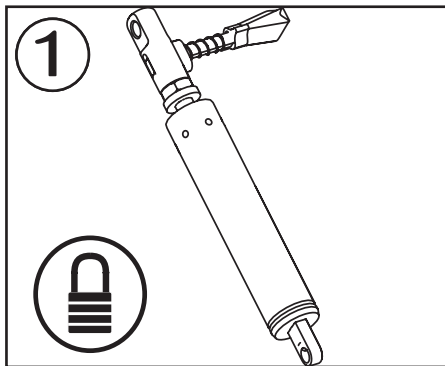
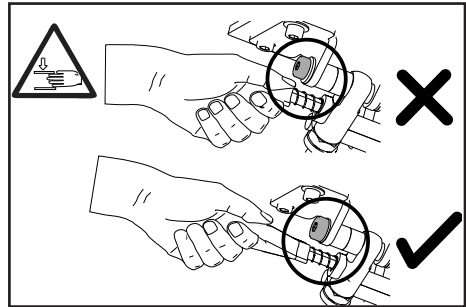
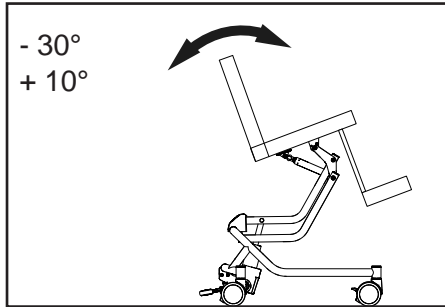

Jenx Limited, Wardsend Road, Sheffield S6 1RQ, United Kingdom  
Tel: +44 (0) 114 285 3376  
Email: [export@jenx.com](mailto:export@jenx.com)  
[www.jenx.com](http://www.jenx.com)

**JENX**®   
Positioning for life

# Chair Height/lock

altura de la silla  
altura da cadeira  
altezza della seduta  
wysokość krzesła

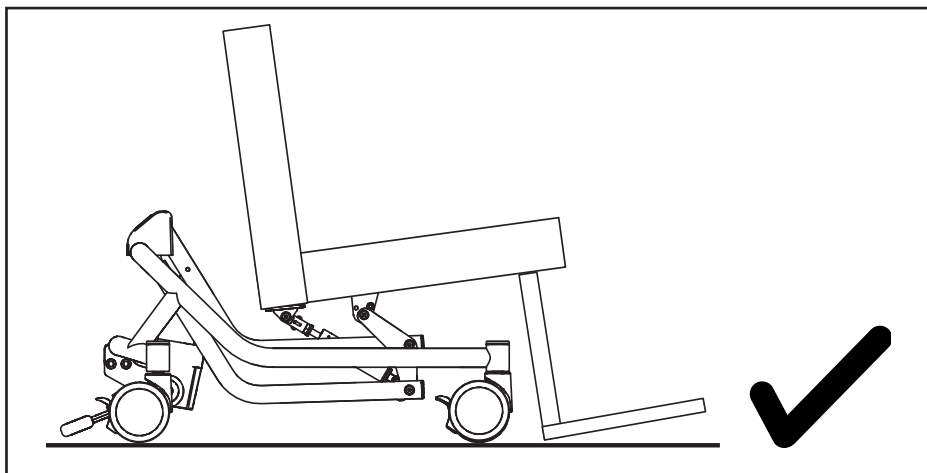
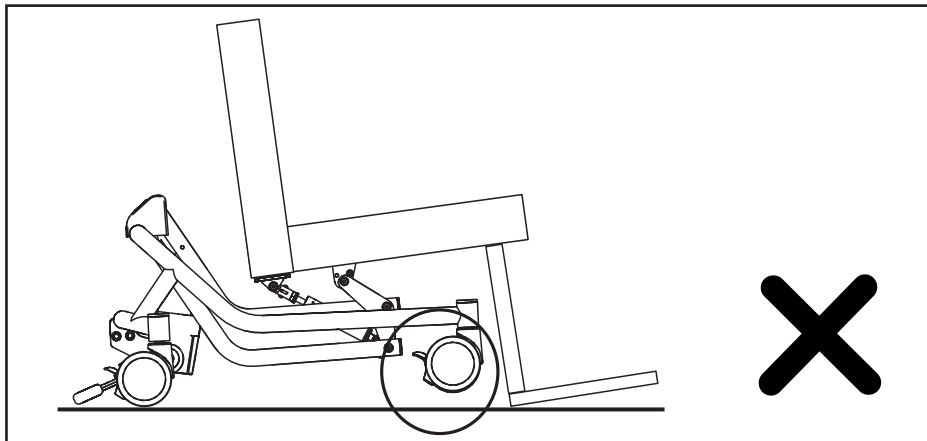

# Chair Height/lock

altura de la silla  
altura da cadeira  
altezza della seduta  
wysokość krzesła

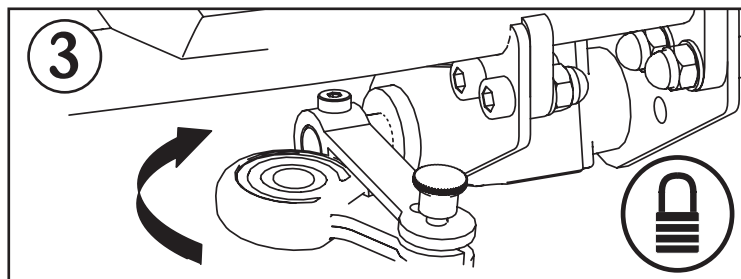
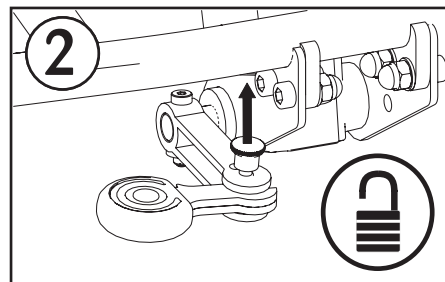
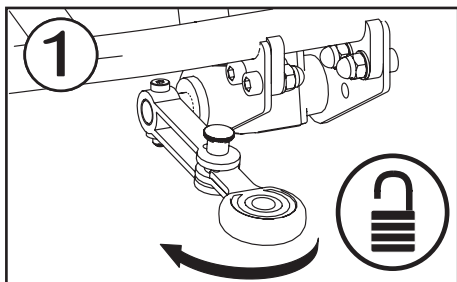
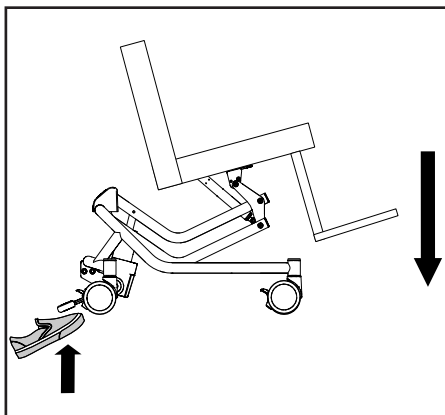
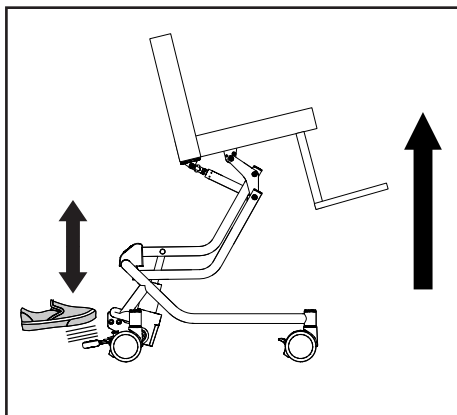

# Notes

notas  
notatki

---

Jenx Limited, Wardsend Road, Sheffield S6 1RQ, United Kingdom  
Tel: +44 (0) 114 285 3376  
Email: [export@jenx.com](mailto:export@jenx.com)  
[www.jenx.com](http://www.jenx.com)

